

Codice 614

Tee a saldare ricavato da tubo elettrounito

- Materiale: Disponibile sia in AISI 304 che in AISI 316
- Welding tee - Butt welding fitting

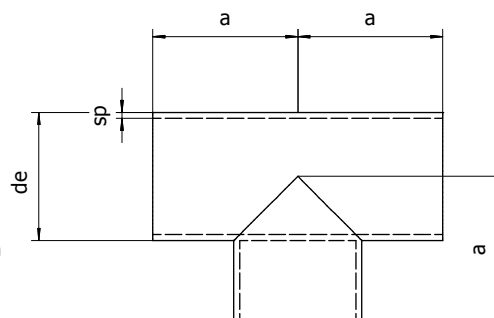
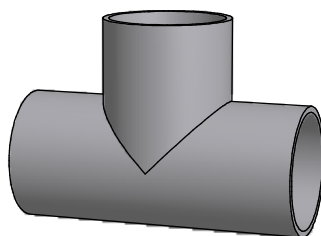

Diametro esterno			Spessore mm. (sp)	Lunghezza mm. (a)
DN	Pollici	mm. (de)		
10	3/8	17,2	2	30
15	1/2	21,3	2	25
			3	
20	3/4	26,9	2	29
			3	
25	1	33,7	2	38
			3	
32	1 1/4	42,4	2	48
			3	
40	1 1/2	48,3	2	57
			3	
50	2	60,3	2	64
			3	
65	2 1/2	76,1	2	76
			3	
80	3	88,9	2	86
			3	
90	3 1/2	101,6	2	105
			3	
100	4	114,3	2	105
			3	
125	5	139,7	2	124
			3	
150	6	168,3	2	143
			3	
200	8	219,1	2	178
			3	
250	10	273	2	216
			3	
300	12	323,9	2	254
			3	

